

WM ES Series

WM R15L100-SPC3-B (stainless steel)

38,1 cm (15") 4:3 LCD

Dimensions: 426 x 301 x 69 mm

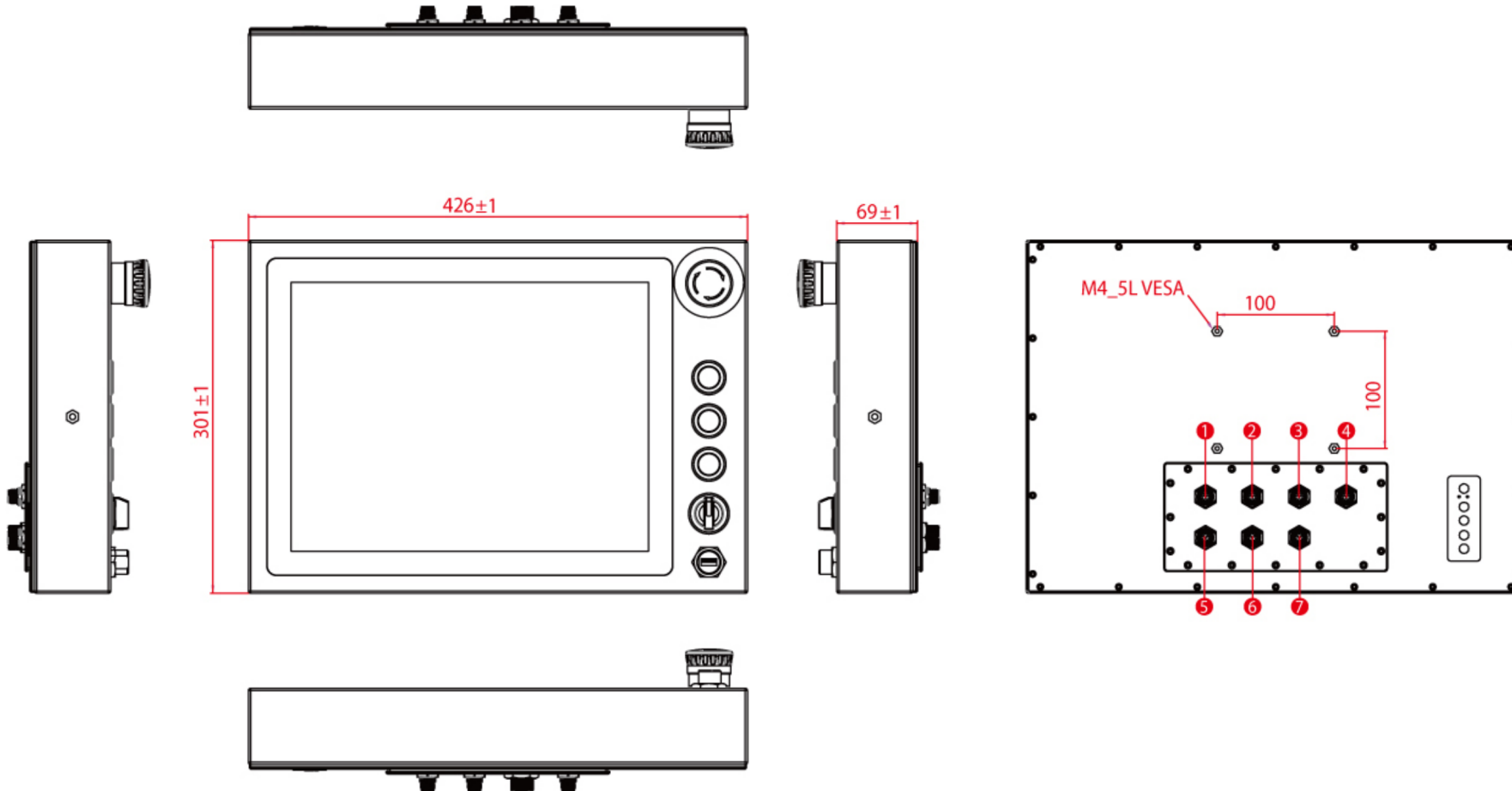

Nº	Description	Nº	Description
①	USB for Touch	⑤	RS232 for Touch mode select
②	USB extension	⑥	VGA
③	CN1(For Emergency Stop & Blue Button)	⑦	Power
④	CN2(For Green & Red Button)		